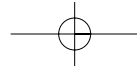
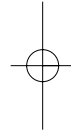
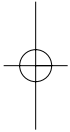
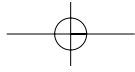
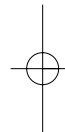
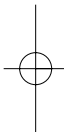
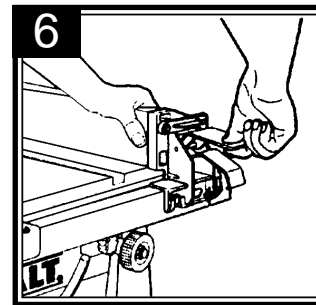
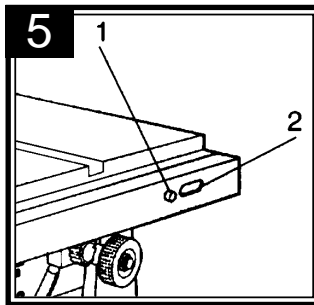
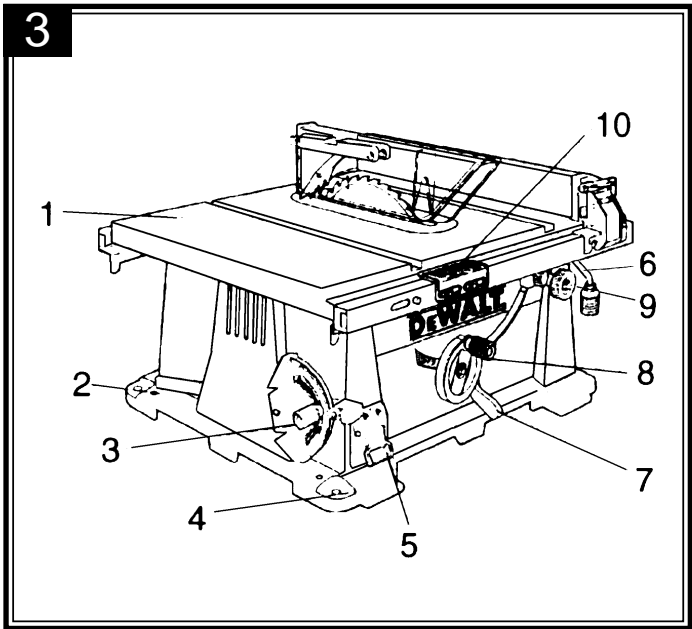
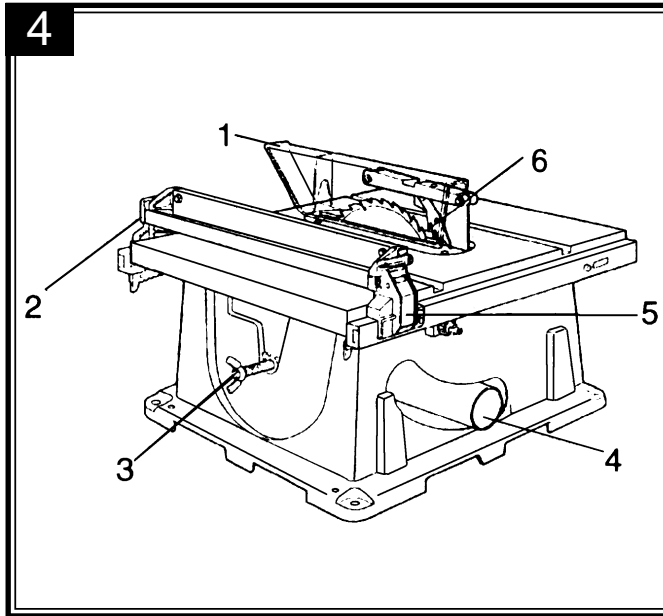
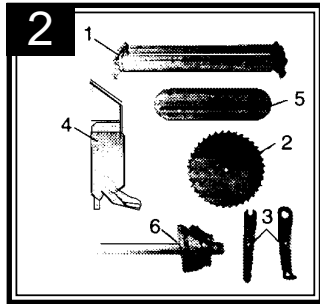
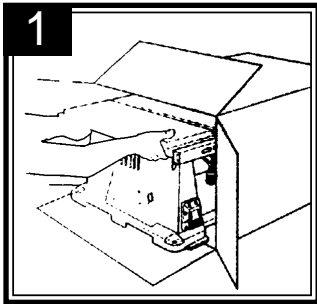
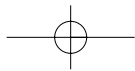


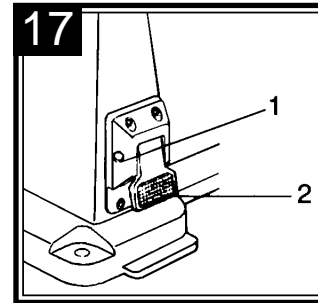
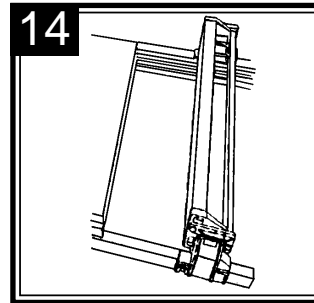
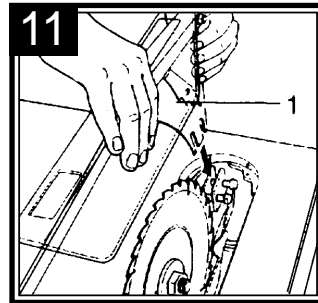
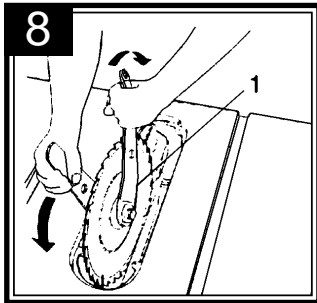
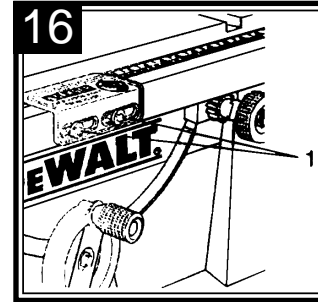
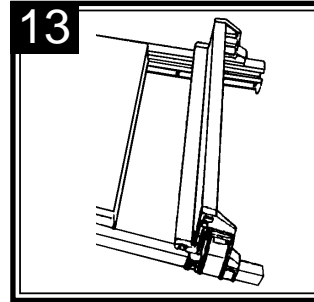
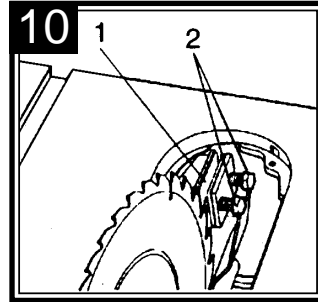
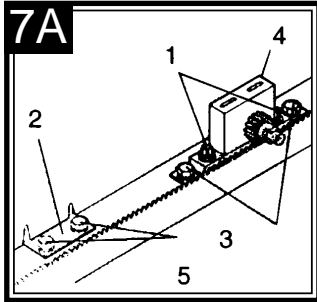
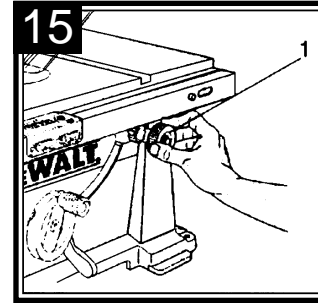
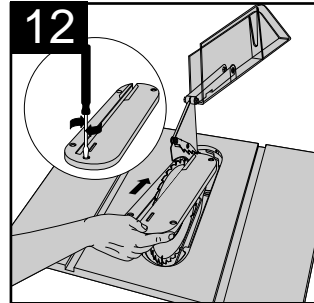
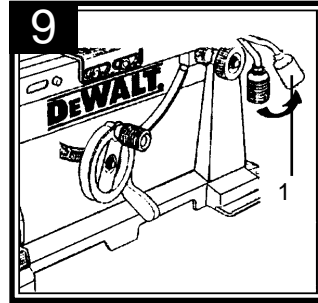
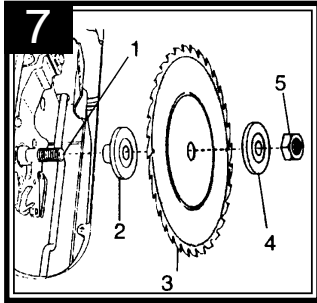
INSTRUCTION MANUAL

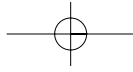
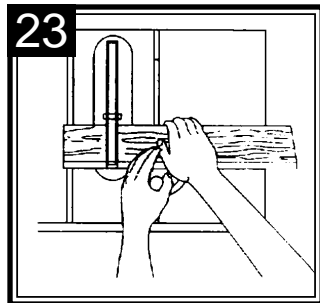
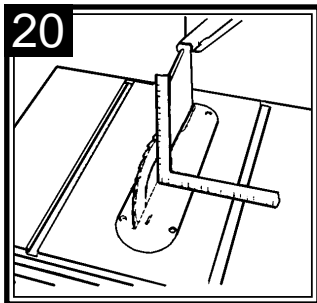
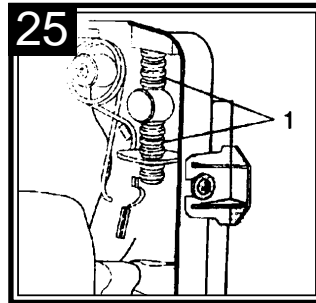
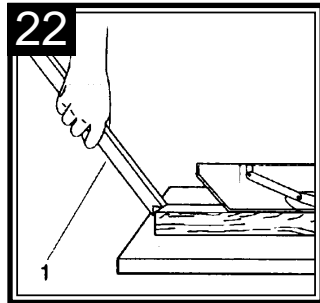
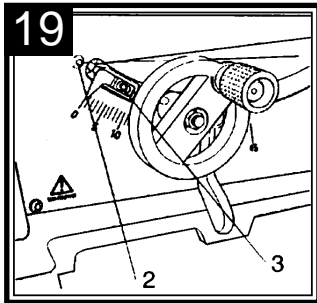
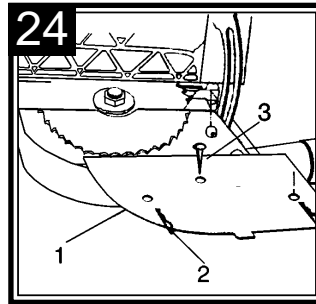
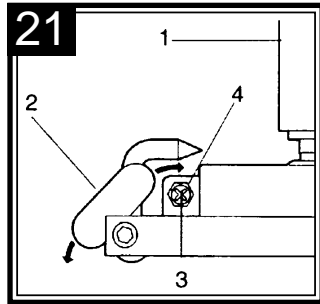
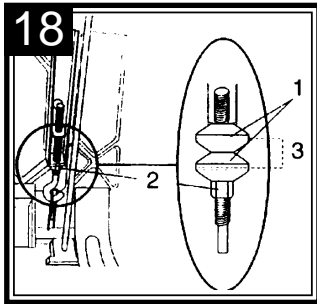
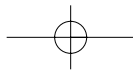


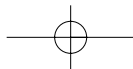
TABLE SAW
MODEL DW744









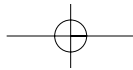


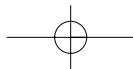
Safety Instructions

When using power tools, always observe the safety regulations applicable in your country to reduce the risk of fire, electric shock and personal injury. Read the following safety instructions before attempting to operate this product. Keep these instructions in a safe place!

General

- 1 Keep work area clean. Cluttered areas and benches can cause accidents.
- 2 Consider work area environment. Do not expose power tools to high humidity or rain. Keep work area well lit. Do not use power tools in the presence of flammable liquids or gases.
- 3 Guard against electric shock. Prevent body contact with earthed surfaces (e.g. pipes, radiators, cookers and refrigerators).
- 4 Keep children away. Do not let children come into contact with the tool or extension cord. Keep all people away from the work area.
- 5 Extension cords for outdoor use. When the tool is used outdoors, always use extension cords intended for outdoor use and marked accordingly.
- 6 Store idle tools. When not in use, power tools must be stored in a dry place and locked up securely, out of reach of children.
- 7 Dress properly. Do not wear loose clothing or jewellery. They can be caught in moving parts. Preferably wear rubber gloves and non-slip footwear when working outdoors. Wear protective hair covering to keep long hair out of the way.
- 8 Wear safety goggles. Also use a face or dust mask in case the operations produce dust or flying particles.
- 9 Be aware of maximum sound pressure. Take appropriate measures for the protection of hearing if the sound pressure of 85dB(A) is exceeded.
- 10 Secure workpiece. Use clamps or a vice to hold the workpiece. It is safer and it frees both hands to operate the tool.
- 11 Do not overreach. Keep proper footing and balance at all times.
- 12 Avoid unintentional starting. Do not carry the plugged-in tool with a finger on the switch. Be sure that the switch is released when plugging in.
- 13 Stay alert. Watch what you are doing. Use common sense. Do not operate the tool when you are tired.
- 14 Disconnect tool. Shut off power and wait for the tool to come to a complete standstill before leaving it unattended. Unplug the tool when not in use, before servicing or changing accessories.
- 15 Remove adjusting keys and wrenches. Always check that adjusting keys and wrenches are removed from the tool before operating the tool.
- 16 Use appropriate tool. Do not force small tools or attachments to do the job of a heavy-duty tool. The tool will do the job better and safer at the rate for which it is intended. The use of any accessories or attachments other than the ones recommended in this instruction manual may induce a risk of personal injury.
- 17 Do not abuse cord. Never carry the tool by its cord or pull it to disconnect from the socket. Keep the cord away from heat, oil and sharp edges.
- 18 Maintain tools with care. Keep tools in good condition and clean for better and safer performance. Follow the instructions for maintenance and changing accessories. Inspect tool cords at regular intervals and, if damaged, have them repaired by an authorised DEWALT Repair Agent. Inspect extension cords periodically and replace them if damaged. Keep all controls dry, clean and free from oil and grease.
- 19 Check damaged parts. Before using the tool, carefully check it for damage to ensure it will operate properly and perform its intended function. Check for misalignment and seizure of moving parts, breakage of parts and any other conditions that may affect its operation. Have damaged guards or other defective parts repaired or replaced as instructed. Do not use the tool if the switch is defective. Have the switch replaced by an authorised DEWALT Repair Centre.
- 20 Have your tool repaired by an authorised DEWALT Repair Centre. This power tool is in accordance with the relevant safety regulations. To avoid danger, electric appliances must only be repaired by qualified technicians.





Description Fig. 2

Figure 2 shows all the loose items and hardware packed with the saw.

1. Rip fence
2. Blade (attached to saw base)
3. Arbor wrench and spindle wrench (attached to saw base)
4. Blade guard
5. Throat plate
6. Mitre gauge

Description Fig. 3

1. Table
2. Screw-down holes
3. Mitre gauge
4. Mounting holes
5. ON-OFF switch
6. Rail lock lever
7. Bevel lock lever
8. Blade height adjustment wheel
9. Fine adjust knob
10. Rip scale indicator

Description Fig 4.

1. Blade guard
2. Work support extension (retracted)
3. Blade/wrench storage
4. Dust exhaust
5. Rip fence latch
6. Anti-kickback teeth

Description Fig. 5

1. Pin
2. Opening

Description Fig. 7

1. Spindle
2. Inner washer
3. Blade
4. Outer washer
5. Arbor nut

Description Fig 7A

1. Torx head bolts
2. Rear pivot bracket
3. 10mm hex bolts

4. Rear pinion bearing assembly

5. Saw shown upside down for clarity

Description Fig. 8

1. Arbor wrench

Description Fig. 9

1. Rail lock lever

Description Fig. 10

1. Shims
2. Bolts

Description Fig. 11

1. Edge of splitter

Description Fig. 15

1. Fine adjust knob

Description Fig. 16

1. Screws

Description Fig. 17

1. Padlock insertion hole
2. ON-OFF Switch

Description Fig. 18

1. Belleville washers
2. Nut
3. Gap

Description Fig. 19

1. Bevel stop cam
2. Bevel stop screw
3. Pointer screw

Description Fig. 21

1. Lock handle
2. Stop plate
3. Adjusting screw
4. Nut

Description Fig. 22

1. Push stick

Description Fig. 24

1. Dust access door
2. Hair pin cotters
3. Central dust cover screw

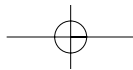
Description Fig. 25

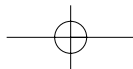
1. Height adjustment threads

Additional Safety Rules for Table Saw

WARNING: For your own safety, do not operate your saw until it is completely assembled and installed according to the instructions and until you have read and understood the following :

- All Safety Rules
- Assembly Procedures
- Operating Controls
- Adjustment Procedures
- Basic Operations
- KEEP guards in place and in working order.
- STABILITY. Make sure table saw is firmly mounted before use.
- MINIMISE ACCIDENT POTENTIAL. Most accidents are caused by failure to follow setup and operating instructions.
- AVOID awkward hand positions, where a sudden slip could cause a hand to move into a saw blade or other cutting tool. Never reach in back of, or around, the cutting tool with either hand to hand down the workpiece. **DO NOT PLACE FINGERS OR HANDS IN THE PATH OF THE SAW BLADE.**
- NEVER reach under your machine when operating or make any adjustments when it is running.
- SHUT OFF the saw and disconnect the power cord when removing the table insert, changing the cutting tool, removing or replacing the blade guard, or making adjustments.
- ALWAYS maintain control of the workpiece. DO NOT let go of the workpiece until it is well clear of the cutting tool.
- WHEN REMOVING short workpieces, or cleaning up around the table, be sure the saw is in the OFF position and blade has stopped turning.
- NEVER turn the saw ON before clearing the table of all tools, wood scraps, etc., except the workpiece and related feed or support devices for the operation planned.
- WHEN changing saw location, disconnect power.
- USE extra caution when the guard assembly is removed for resawing, dadoing, rabbeting, or moulding. Replace the guard as soon as that operation is completed.
- NEVER hold onto or touch the "free end" of the workpiece or a "free piece" that is cut off, while power is ON and/or the saw blade is rotating.





- IF YOU STALL OR JAM the saw blade in the workpiece, turn saw OFF, remove the workpiece from the saw blade, and check to see if the saw blade is parallel to the mitre gauge slots or grooves and if the splitter is in proper alignment with the saw blade. If ripping at the time, check to see if the rip fence is parallel with the saw blade. Readjust as indicated.

WARNING: Do not allow familiarity (gained from frequent use of your saw) to replace following safety rules. Always remember that a careless fraction of a second is sufficient to inflict severe injury.

- **MAKE SURE** your fingers do not contact the terminals of the power cord when installing or removing the plug to or from the line power source.
- **KICKBACKS** - Kickbacks can cause serious injury. A kickback occurs when a part of the workpiece binds between the saw blade and the rip fence, or other fixed object, and rises from the table and is thrown toward the operator. Kickbacks can be avoided by attention to the following conditions:
- **NEVER** leave the saw turned ON and unattended.
- **NEVER** attempt to remove gum or resin from a saw blade in motion. Ensure the blade has completely stopped and the electrical power is turned OFF.
- **NEVER** insert wedges between the blade flange and the blade to form what is known as a wobble saw.

KICKBACKS - HOW TO AVOID THEM AND PROTECT YOURSELF FROM POSSIBLE INJURY.

- Be certain that the saw blade is parallel to the rip fence. Adjust fence if not parallel.
- Do not rip by applying the feed force to the section of the workpiece that will become the cut-off (free) piece. Feed force when ripping should always be applied between the saw blade and the fence...use a push stick for short work, 6" (152 mm) wide or less. For less than 2" (52 mm) wide, you must use a special fixture.
- Keep saw blade guard, splitter and anti-kickback teeth in place and operating properly. Keep teeth sharp. If teeth are not operational, return your unit to the nearest DEWALT Service Centre for repair. The splitter must be in alignment with the saw blade and the teeth must stop a kickback once it has started. Check their action before ripping by pushing the wood under the anti-kickback teeth. The teeth must prevent the wood from being pulled toward the front of the saw.
- Plastic and composition (like hardboard) materials may be cut on your saw. However, since these are usually quite hard and slippery, the anti-kickback teeth may not stop a kickback. Therefore, be especially attentive to following proper set up and cutting procedures for ripping.
- Use saw blade guard and splitter for every operation for which it can be used,

including all through sawing.

- **DO NOT** leave a long board (or other workpiece) unsupported so the spring of the board causes it to shift on the table. Provide proper support for the workpiece, based on its size and the type of operation to be performed. Hold the work firmly against the fence and down against the table surface.
 - **NEVER** use a length stop on the free end of the workpiece when crosscutting. Never hang onto or touch the free end of the workpiece when crosscutting, or a free piece that is cut off when ripping while power is ON and/or the saw blade is rotating. In short, the cut-off piece in any through sawing (cutting completely through the workpiece) operation must never be confined – it must be allowed to move away from saw blade.
 - IF YOUR SAW makes an unfamiliar noise or if it vibrates excessively, cease operating immediately until the source has been located and the problem corrected.
 - **KEEP OUT** of the line of saw blade. Stand to the side whenever possible.
 - **USE** a push-stick when required.
 - **PAY** particular attention to instructions on reducing risk of kickback.
 - **DO NOT** perform any operation free hand.
 - **NEVER** reach around, behind or over saw blade.
 - **USE RECOMMENDED ACCESSORIES.** The use of improper accessories may cause risk of personal injury.
- ⚠ **CAUTION:** Some wood contains preservatives such as copper chromium arsenate (CCA) which can be toxic. When cutting these materials extra care should be taken to avoid inhalation and minimise skin contact.
- **USE A DUSTMASK** and safety glasses when sawing. This saw is capable of generating large amounts of sawdust.

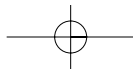
SAVE THESE INSTRUCTIONS FOR FUTURE USE

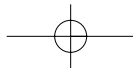
Extension Cords

Use only extension cords that are approved by the country's electrical authority. Before using an extension cord, inspect it for loose or exposed wires, damaged insulation and defective fittings. Replace the cord if necessary.

Replacement of the Supply Cord

If the supply cord is damaged, it must be replaced by the manufacturer or its service agent or similarly qualified person in order to avoid a hazard.





Specifications

Table Size:	19 1/4" (489 mm) x 26 1/2" (673 mm)
Mitre Angle:	30° L&R
Bevel Angle:	0° to 45°L
Blade Size:	10" (254 mm)
Max. Cut Depth:	0° Bevel3 1/8" (79 mm)
Max. Cut Depth:	45° Bevel2 1/4" (57 mm)
RPM, no load:	3650 rpm

Unpacking

Open the box and slide the saw out, as shown in Fig. 1.

Carefully unpack the table saw and all loose items from the carton. Examine all parts to make sure that parts have not been damaged during shipping. If any parts are missing or damaged, contact your dealer to replace them before attempting to assemble the tool.

Examine Fig. 3 & 4 to become familiar with the saw and its various parts. The following sections on assembly and adjustments will refer to these terms and you must know what and where the parts are.

ASSEMBLY

YOUR SAW SHOULD BE ASSEMBLED IN THE FOLLOWING ORDER:

1. Blade
2. Rip fence (NOTE: Adjust rip scale before proceeding. See "Adjusting Rip Scale" pg 5).
3. Blade guard
4. Throat plate

Tools needed for assembly include a screwdriver and the wrenches included with your saw.

ASSEMBLING THE RIP FENCE

The rip fence can be installed on the left or right side of your table saw.

1. Locate the pin and opening on fence rails, as shown in Figure 5. Align the pin with the slot and align the latch with the opening.
2. Secure the rip fence by snapping the latches onto the rails as shown in Figure 6. Be sure to snap both latches in place.

ATTACHING/REPLACING THE BLADE

1. THE SAW MUST BE UNPLUGGED BEFORE YOU MAKE ANY ADJUSTMENT TO THE BLADE.
2. Raise the saw blade arbor to its maximum height by turning the blade height adjustment wheel clockwise.
3. Remove the arbor nut and flange from the saw arbor by turning counterclockwise.
4. Place the saw blade on to the spindle making sure the teeth of the blade point down at the front of the table. Assemble the washers and arbor nut to the spindle and tighten arbor nut as far as possible by hand, making sure that the saw blade is against the inner washer and the large washer diameters are against the blade. Ensure the side of outer washer marked "Blade Side" is against the blade (see Fig. 7). Ensure the spindle and washers are free from dust and debris.
5. To keep the spindle from rotating when tightening the arbor nut, use the open-ended spindle wrench to secure the spindle (see Fig 8).
6. Using the arbor wrench, tighten arbor nut by turning it clockwise (see Fig. 8).
7. NOTE: Different types of blades make different kerfs (width of cuts). Therefore, it is necessary to check adjustment of rip fence pointer and blade guard splitter when changing blades.

ADJUST BLADE ALIGNMENT TO TABLE

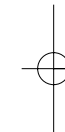
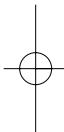
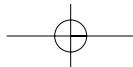
1. THE SAW MUST BE UNPLUGGED BEFORE YOU MAKE ANY ADJUSTMENT TO THE BLADE.
2. Place the unit in an upright position. Using a 10 mm socket, loosen rear pivot bracket fasteners just enough to allow the bracket to move side-to-side. (Fig. 7a)
3. Adjust the bracket until the blade is parallel to the mitre gauge slot.
4. Tighten the rear pivot bracket fasteners to 7-8 lb-ft (9-11 Nm).

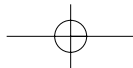
ADJUSTING THE RIP SCALE

1. Unlock the rail lock lever (see Fig. 9).
2. Set the blade at 0° bevel and move the fence in until it touches the blade.
3. Lock the rail lock lever.
4. Loosen the rip scale pointer screws (see Fig. 16) and set the rip scale pointer to read zero (0). Retighten the rip scale pointer screws. The rip scale reads correctly only when the fence is mounted on the right side of the blade.

ATTACHING THE BLADE GUARD

1. Raise the saw blade arbor to its maximum height by turning the blade height adjustment wheel clockwise.
2. Loosen, but do not remove the two bolts shown in Fig. 10.
3. Align the slots on the blade guard with the bolts shown in Fig. 10. Insert the





blade guard as shown in Fig. 11, ensuring the bolts fit into the slots on the blade guard. The top of the slots must rest on the bolts. The bottom edge of the splitter should be aligned with the blade (see Fig. 10). If the blade and splitter are not aligned, remove the blade guard and reinsert it after adjusting the shims. These shims allow for precision alignment of the blade and splitter.

4. Retighten the bolts securely.

WARNING: Before connecting the table saw to the power source or operating the saw, always inspect the guard and splitter for proper alignment and clearance with the saw blade. Check alignment after each change of bevel angle.

When properly aligned, the splitter will be in line with the blade at both table top level, and at the top of the blade. Check using the straight edge. With power disconnected, operate the blade tilt and height adjustments through the extremes of travel and insure the guard clears the blade in all operations and that the anti-kickback teeth are functioning.

Attaching the Throat plate

1. Align the throat plate as shown in Figure 12, and insert the tabs on the back of the throat plate into the holes on the back of the table.
2. Press down on the front of the throat plate to snap it into place.
3. The throat plate includes four adjustment screws which raise or lower the throat plate. When properly adjusted, the front of the throat plate should be flush or slightly below the surface of the table top and secured in place. The rear of the throat plate should be flush or slightly above the table top.
4. Turn the cam lock screw (Detail Fig. 12) clockwise 1/4 turn to lock the throat plate in place.

CAUTION: The throat plate must be in place at all times.

Bench Mounting

TURN OFF AND UNPLUG TABLE SAW

The table saw must be mounted firmly. The mounting surface must have a 15" (380 mm) by 20" (508 mm) opening to allow dust to escape. Four holes are provided in the tool's feet for mounting. We strongly recommend that these holes be used to anchor the table saw to your workbench or other stationary rigid frame. Alternately, to enhance the saw's portability, it can be mounted to a piece of wood that can be "C" clamped to your work surface, stand or Workmate. The DEWALT DW7440 Table Saw Stand is designed for use with this saw, and is available from your local DEWALT dealer or service center.

CAUTION: Failure to securely mount the table saw to the work surface can be hazardous.

1. Centre the saw on a square piece of 1/2" (12.7 mm) plywood. The plywood must have a 15" (380 mm) by 20" (508 mm) opening to allow dust to escape.
2. Mark the positions of the four mounting holes in the base of the saw with a pencil.
3. Remove the saw and drill 1/4" (6.4 mm) holes in the places you have just marked.
4. Position the saw over the four holes you drilled in the plywood and insert four 1/4" (6.4 mm) machine screws FROM THE BOTTOM. Install washers and 1/4" (6.4 mm) nuts on the top. Tighten securely.
5. In order to prevent the screw heads from marring the surface to which you clamp the saw, attach two strips of scrap wood to the bottom of the plywood base. These strips can be attached with glue, or wood screws can be installed from the top side as long as they don't protrude through the bottom of the strip.
6. "C" clamp the plywood base to your workbench whenever you want to use the saw.

CAUTION: Make sure table saw is firmly mounted before use.

Connecting Saw to Power Source

IMPORTANT: Before connecting saw to power source, make sure the switch is in the OFF position.

Be sure your power supply agrees with the nameplate marking. A voltage decrease of 10 percent or more will cause a loss of power and overheating. All DEWALT tools are factory tested. If this tool does not operate, check the power supply.

Rip Fence Operation

RAIL LOCK LEVER

The rail lock lever locks the rip fence rails in place, preventing their movement. To lock the rail lock lever, push it down. To unlock the lever, pull it up (see Fig. 9).

NOTE: When ripping, always lock the rail lock lever.

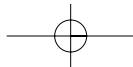
WORK SUPPORT EXTENSION

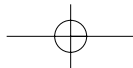
Your table saw is equipped with a work support extension to support work that extends beyond the saw table. To use the work support extension, rotate it as shown in Fig. 13. When not in use, the work support extension retracts, as shown in Fig. 14.

NOTE: Retract the work support extension whenever working over the table.

FINE ADJUST KNOB

The fine adjust knob (shown in Fig. 15) allows smaller adjustments when setting the fence. Before adjusting, be sure the rail lock lever is in its up, or unlocked, position.





RIP SCALE POINTER

NOTE: The rip scale pointer will need to be readjusted whenever a thicker or thinner blade is installed.

On-Off Switch

Lift the switch paddle up to turn your saw ON and push it down to turn your saw OFF.

A hole is provided in the switch for insertion of a padlock to lock the saw off (Fig. 17).

WARNING: Be sure switch is in the OFF position before plugging machine in.

Adjustments

NOTE: All settings on your saw have been accurately adjusted at the factory.

RAIL LOCK ADJUSTMENT

1. Lock the rail lock lever (Fig. 9) by pushing down.
2. On the underside of your saw, tighten the nut shown in Figure 18. Adjust this nut until the gap between the belville washers closes.
3. Once the springs are almost touching, loosen the nut 1/2 turn.

RIP SCALE ADJUSTMENT

See "ADJUSTING THE RIP SCALE" on page 5.

BEVEL STOP AND POINTER ADJUSTMENT

1. Raise the blade fully by rotating the blade height adjustment wheel clockwise until it stops.
2. Unlock the bevel lock lever (Fig. 3) by pushing it up and to the right. Loosen the bevel stop screw (Fig. 19).
3. Place a square flat against the table top and against the blade between teeth, as shown in Fig. 20. Ensure the bevel lock lever is in its unlocked, or up, position.
4. Using the bevel lock lever, adjust the bevel angle until it is flat against the square.
5. Tighten the bevel lock lever by pushing it down.
6. Turn the bevel stop cam until it firmly contacts the bearing block. Tighten the bevel stop screw.
7. Check the bevel angle scale. If the pointer does not read 0°, loosen pointer screw (see Fig. 19) and move the pointer so it reads correctly. Retighten the pointer screw.
8. Repeat at 45°, but do not adjust pointer.

MITRE GAUGE ADJUSTMENT

Your mitre gauge features adjustable stops at 90° and 45° left and right. To adjust these stops, loosen the lock nuts and tighten or loosen the three adjusting screws against the stop plate (see Fig. 21).

FENCE PARALLEL ADJUSTMENT

1. Unlock rail lock lever.
2. Locate rear pinion bearing and loosen the two hex bolts just enough to allow side-to-side movement.
3. Adjust fence parallel to blade.
4. Lock rail lock lever and check parallel alignment of the blade.
5. Tighten the 2 hex bolts that secure the rear pinion bearing assembly to the table.

NOTE: If there is not enough travel in the pinion bearing assembly to allow the fence to be parallel to the blade, take the unit to an authorised service centre.

RACK AND PINION MESH ADJUSTMENT

Proper adjustment of the rack and pinion mesh is done at the factory. If it should become necessary to adjust the rack and pinion mesh, use the following procedure.

1. Turn the saw upside down and locate the front pinion bearing.
2. Using a narrow blade screw driver or #20 torx driver, access the screw through the slot. Loosen the screw (counterclockwise) until the head touches the inside of the bearing box.
3. Tighten the screw (clockwise) 3/4 of a turn.
4. Repeat procedure for rear pinion bearing

Saw Blades

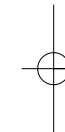
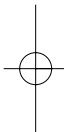
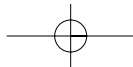
THIS SAW IS INTENDED FOR THE USE OF BLADES 10" IN DIAMETER OR SMALLER

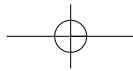
1. The saw blade furnished with your new saw is a 10" (254mm) combination blade, used for cross cutting (across the grain) and ripping (with the grain) through the material. This blade will produce a good quality cut for most applications.
2. There are many types of blades available to do specific and special jobs such as cross cut only, rip only, hollow ground, thin plywood, paneling, etc.
3. Use only saw blades designed for maximum safe operating speeds of 5,000 RPM or greater.
4. Saw blades should always be kept sharp. It is recommended that you locate a reputable sharpening service to sharpen your blades when needed.
5. Never stack blades on top of one another to store. Place material such as cardboard between them to keep the blades from coming in contact with one another.

⚠ CAUTION: Abrasive wheels should not be used on this saw.

Kickback

Kickback is a dangerous condition! It is caused by the workpiece binding against the blade. The result is that the workpiece can move rapidly in a direction opposite to the





feed direction. During kickback, the workpiece could be thrown back at the operator. It can also drag the operator's hand back into the blade if the operator's hand is at the rear of the blade. If kickback occurs, turn the saw OFF and verify the proper functioning of the splitter, anti-kickback teeth and guards before resuming work.

⚠ CAUTION:

1. Always use the guard and make certain it is in good working order. The guard's splitter helps prevent binding and the anti-kickback teeth on each side of the splitter minimise the possibility of kickback. Use extra caution until the workpiece is through the splitter and has engaged anti-kickback teeth.
2. Do not saw warped, bowed or cupped wood. The workpiece must have one straight, smooth side to go against the rip fence or mitre gauge. The workpiece must sit flat on the table without rocking.
3. Do not cut "free hand". Always use either the rip fence or the mitre gauge. Never use both.
4. Use extra care when the guard assembly cannot be used (during dadoing or moulding).
5. Support large workpieces carefully. Allowing them to sag or droop can cause kickback.

Operation

Plain sawing includes ripping and cross cutting, plus a few other standard operations of fundamental nature. The following methods feature safety. As with all power tools respecting the tool, using caution and following safe practices will considerably lessen the possibility of personal injury. However, if normal safety precautions are overlooked or completely ignored, personal injury to the operator can result. Read and follow all warnings indicated on the saw. Through sawing is any operation which renders the material into two separate pieces. Observe the safety rules included in this manual. THIS SAW IS NOT INTENDED FOR CUTTING METAL.

Operating Instructions

There are two basic types of cuts: ripping and crosscutting. In general, cutting with the grain is ripping and across the grain is crosscutting. However, with man made materials this distinction is somewhat difficult to make. Therefore, cutting a piece of wood to a different width is ripping and cutting across the short dimension is crosscutting. Neither ripping or crosscutting may be done safely freehand! Ripping requires the use of the rip fence and crosscutting uses the mitre gauge.

CAUTION: Before using the saw each and every time verify the following:

1. Blade is tight.

2. Bevel angle lock knob is tight.
 3. If ripping, ensure rail lock lever is tight and fence is parallel to the blade.
 4. If crosscutting, mitre gauge lever is tight.
 5. Guard is in place and working properly.
 6. Safety glasses are being worn.
 7. The blade guard is properly attached and the anti-kickback teeth are functioning.
- Failure to adhere to these common safety rules can greatly increase the likelihood of injury.

Ripping

1. Lock the rip fence by pressing the rail lock lever down. Remove the mitre gauge.
2. Raise the blade so it is about 1/8" (3.2 mm) higher than the top of the workpiece.
3. Hold the workpiece flat on the table and against the fence. Keep the workpiece about 1" (25.4 mm) away from the blade.

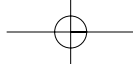
⚠ CAUTION: The workpiece must have a straight edge against the fence and must not be warped, twisted or bowed. Keep both hands away from the blade and away from the path of the blade.

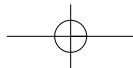
4. Turn the saw on and allow the blade to come up to speed. Both hands can be used in starting the cut. When there is approximately twelve (12) inches (305 mm) left to be ripped use only one hand, with your thumb pushing the material, your index and second finger holding the material down and your other fingers hooked over the fence. Always keep your thumb along side your first two fingers and near the fence.
5. Keeping the workpiece against the table and fence, slowly feed the workpiece rearward all the way through the saw blade. Continue pushing the workpiece until it is clear of the guard and it falls off the rear of the table. Do not overload the motor.
6. Never try to pull the workpiece back with the blade turning. Turn the switch off, allow the blade to stop, raise the anti-kickback teeth on each side of the splitter if necessary and slide the workpiece out.
7. When sawing a long piece of material or a panel, always use a work support. A sawhorse, rollers, or out feed assembly provides adequate support for this purpose. The work support must be at the same height as the saw table.

⚠ CAUTION: Never push or hold onto the "free" or "cut off" side of the workpiece.

Bevel Ripping

This operation is the same as ripping except the bevel angle is set to an angle other than zero (0) degrees.





WARNING: Before connecting the table saw to the power source or operating the saw, always inspect the guard and splitter for proper alignment and clearance with saw blade. Check alignment after each change of bevel angle.

Ripping Small Pieces

It is unsafe to rip small pieces. It is not safe to put your hands close to the blade. Instead, rip a large piece to obtain the desired piece. When a small width is to be ripped and the hand cannot be safely put between the blade and the rip fence, use one or more push sticks. Use them to hold the workpiece against the table and fence, and push the workpiece against the table and fence, and push the workpiece fully past the blade. See Fig. 22.

Crosscutting

1. Remove the rip fence and place the mitre gauge in the desired slot.
2. Adjust the blade height so that the blade is about 1/8 (3.2 mm) higher than the top of the workpiece.
3. Hold the workpiece firmly against the mitre gauge with the path of the blade in line with the desired cut location. Keep the workpiece an inch or so in front of the blade. **KEEP BOTH HANDS AWAY FROM THE BLADE AND THE PATH OF THE BLADE.**
4. Start the saw motor and allow the blade to come up to speed.
5. While using both hands to keep the workpiece flat against the face of the mitre gauge, and holding the workpiece flat against the table, slowly push the workpiece through the blade. See Fig. 23.
6. Never try to pull the workpiece with the blade turning. Turn the switch OFF, allow the blade to stop, and carefully slide the workpiece out.

CAUTION: Never touch or hold onto the "free" or "cut off" end of the workpiece.

Bevel Crosscutting

This operation is the same as crosscutting except that the bevel angle is set to an angle other than 0°.

WARNING: Before connecting the table saw to the power source or operating the saw, always inspect the guard and splitter for proper alignment and clearance with saw blade. Check alignment after each change of bevel angle.

Mitreing

This operation is the same as crosscutting except the mitre gauge is locked at an angle other than 0°. Hold the workpiece **FIRMLY** against the mitre gauge and feed the workpiece slowly into the blade (to prevent the workpiece from moving). See Fig. 23.

MITRE GAUGE OPERATION

To set your mitre gauge, loosen the lock handle and move the mitre gauge to the desired angle. The mitre gauge has set stops and 90° and 45° left and right. To rotate the mitre gauge beyond these stops, flip the stop plate up, as shown in Fig. 21.

Compound Mitreing

This is a combination of bevel crosscutting and mitreing. Follow the instruction for both bevel crosscutting and mitreing.

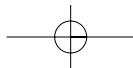
Dado Cutting

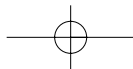
CAUTION: Do not attempt to stack dado blades thicker than 13/16" (20 mm). Do not use dado blades larger than 8" (200 mm) diameter. Since dado cuts are not through cuts, the cuts must be performed with the blade guard removed. To remove the blade guard, loosen the two bolts shown in Fig. 10 and remove the guard assembly.

When using the dado, (sold as an accessory) the special dado insert (also sold as an accessory) must be used.

Any time a cut is required that is considerably wider than the saw kerf, a dado is used. A dado cut is commonly used to add support and line up a shelf for a cabinet, bookcase or some such project. When using the dado, the guard must be removed. Use **EXTREME** care when using the dado without the guard. If a deep cut is required use several successive passes rather than attempting to make it with one pass. Maximum dado width on this saw is 13/16" (20 mm). **DO NOT USE WIDER COMBINATIONS.**

CAUTION: Always check dado blade clearance before plugging in the saw. Be sure to place the guard back in position and check adjustments when the dado cuts are complete.





Dust Collection

Your table saw is equipped with a dust shroud and dust collection port. For best results, connect a vacuum to the port at the rear of the saw. If the saw is operated without a vacuum attached, most of the dust will be blown out of the dust collection port. However, some dust will fall inside the base. If the saw is used on a table or other surface without an opening on the bottom, clean out the base and accumulated saw dust after each cut. After extended use, the saw's dust collection system may become clogged. To clear the dust collection system:

- a) Unplug the saw.
- b) Turn the saw on its side, so the bottom, open part of the unit is accessible.
- c) Open the dust access door shown in Fig. 24 by removing the two hair pin cotters or the central retaining screw on the dust cover. Clean out the excess dust, and re-secure the access door with the hair pin cotters or the central dust cover screw.

When cutting wet wood without a vacuum or when cutting with a dado blade, removing the dust access door may be helpful in preventing clogs.

Lubrication

1. All motor bearings are permanently lubricated at the factory and no additional lubrication is needed.
2. The height adjustment screw may require periodic cleaning and lubrication. If you have difficulty raising or lowering the blade:
 - a) Unplug the saw.
 - b) Turn the saw on its side, so the bottom, open part of the unit is accessible.
 - c) Clean and lubricate the height adjustment screws threads on the underside of your saw with general purpose grease, as shown in Fig. 25.

Cleaning

Use only mild soap and damp cloth to clean the tool. Never let any liquid get inside the tool; never immerse any part of the tool into a liquid. Never use solvents to clean saw or guard components.

Important

To assure product SAFETY and RELIABILITY, repairs, maintenance and adjusting (including brush inspection and replacement) should be performed by authorised service centres or other qualified service organisations, always using identical replacement parts.

DEWALT After-Sales Service

All DEWALT power tools are thoroughly tested before leaving the factory. However, if the power tool needs repair, please contact your dealer or take it to your nearest DEWALT Service Centre.

Guarantee

Full One Year Warranty

DEWALT heavy duty industrial tools are warranted for one year from date of purchase. We will repair, without charge, any defects due to faulty materials or workmanship. Arrangements have been made with the Industrial Tool Division of Black & Decker to provide warranty repairs for DEWALT tools. Please return the complete unit, transportation prepaid, to any DEWALT Service Centre, Black & Decker Service Centre or any authorised service station. This warranty does not apply to:

- Accessories
- Damage caused where repairs have been made or attempted by others
- Damage due to misuse, neglect, wear and tear, alteration or modification.

Free One Year Service Contract

In addition to a full one year warranty, every DEWALT tool is backed with a Free One Year Service Contract. We will provide free labour on all repair and preventative maintenance during the first year after purchase. Proof of purchase date is required.

30 Day No Risk Satisfaction Guarantee

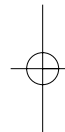
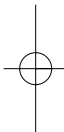
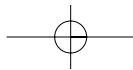
If you are not completely satisfied with the performance of your DEWALT heavy duty industrial tool, simply return it to the participating seller within 30 days. Proof of purchase date is required.

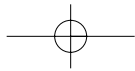
Unwanted Tools and the environment

Take your old tool to an authorised DEWALT Repair Agent where it will be disposed of in an environmentally safe way.

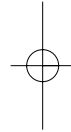
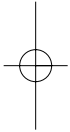
NOTES:

- DEWALT reserves the right to change or upgrade the product specifications or standard equipment at any time without notice.
- Standard equipment and accessories may vary by country.
- Product specifications may differ by country.
- Complete product range may not be available in all countries. See your local DEWALT dealer for range availability.





NOTE: THIS INSTRUCTION MANUAL IS APPLICABLE FOR THE FOLLOWING SUB-CODES: -XE



DeWALT INDUSTRIAL TOOL COMPANY

COPYRIGHT © 1998, 1999

Form# 387486-01

